

brent[®] SLAB ROLLERS



6060 Guion Road • Indianapolis, Indiana 46254-1222 USA
(800) 374-1600 • Fax: (317) 248-9300 • www.amaco.com



Dear Customer,

We hope you enjoy your new brent® slab roller. Many different people are involved in the fabrication and manufacturing of each brent® product. We all work together to build the best equipment possible.

These sturdy machines are constructed of heavy gauge steel pipe and plate, precision machined parts, permanently sealed bearings, and aircraft quality cables. The beds consist of masonite shims which can be removed or added to vary the slab thickness. A canvas covered removable shim that absorbs water from the clay is used so you can peel off the clay slab easily. The entire shim with clay slab can be removed from the bed. An optional stand may be purchased to attach a brent® hand-extruder to the end of our SR model slab rollers.

Please fill out your product registration card and return it to us, as we are interested in your comments.

We believe our service to you is as important as the service you expect from your slab roller.

For that reason, if you have any questions, or if you need parts in the future, please call the brent® Service Department on our toll-free number, (800) 999-5456, Monday through Friday, 7:00 am to 3:30 pm Eastern Standard Time.

Slab Roller Assembly

brent® MODEL SRC

SET UP:

1. Lift machine out of box. If you have purchased the leg set, the legs can be easily screwed in using a pipe wrench. A strap-type pipe wrench (such as those used for chromed pipes) will not scratch off the paint, or use a rag around the pipe wrench jaws.
2. Bolt the wooden crank handle to the crank arm with the nut and lock-nut. Your machine is now ready for use.

MAINTENANCE:

1. Normal maintenance for the SRC consists of periodically checking the cables for looseness. Do this by cranking the rollers to the center of the machine and pinching the two cables together half way between the roller and the end. You should not be able to squeeze them closer than one inch. If they go closer they are too loose. Tighten them by tightening the cable adjustment nut (see drawing below).
2. If the cables become frayed or worn you can obtain new ones from brent®. The correct cable wrap is shown on the drawing below. First remove the masonite shims and the particle board bed and then tape or tie the two rollers together to hold them in place while removing the old cables and

installing the new ones. Before you wrap the new cables, be sure the rollers are perpendicular to the frame. Wrap the handle side as shown starting with the lower cable at the end opposite the cable adjustment. The opposite side is a mirror image of the one shown in the drawings. When the cables are in place, take up the slack with the cable adjustment bolt, but do not tighten very tightly. Now remove the tape and crank the rollers to one end and keep turning the crank until the bottom roller hits the leg coupling on both sides. The rollers are now squared with the frame and you can tighten the cables as described in Step 1. Re-check the tension after rolling a few slabs.

NOTE: Occasionally rolling clay off center from middle of bed will cause roller to lose its adjustment. If your top roller is not parallel to the rail frame, call our brent® Service Department for adjustment instructions.

Toll Free: 1-800-999-5456

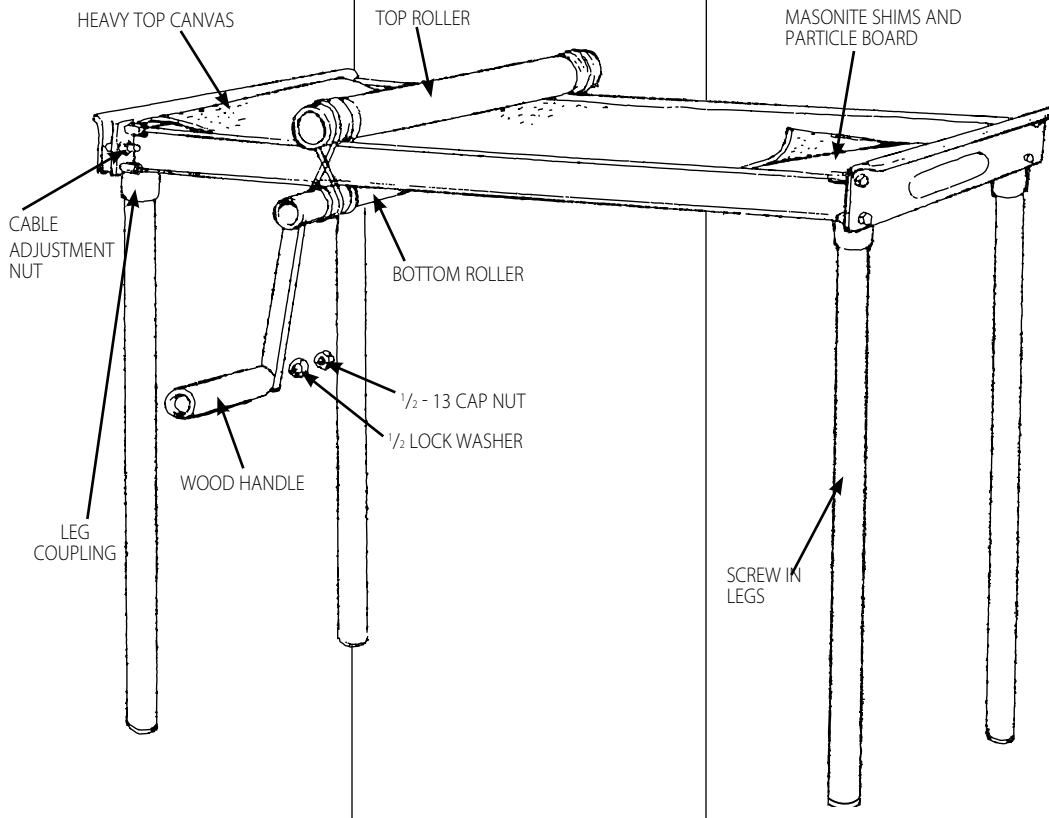
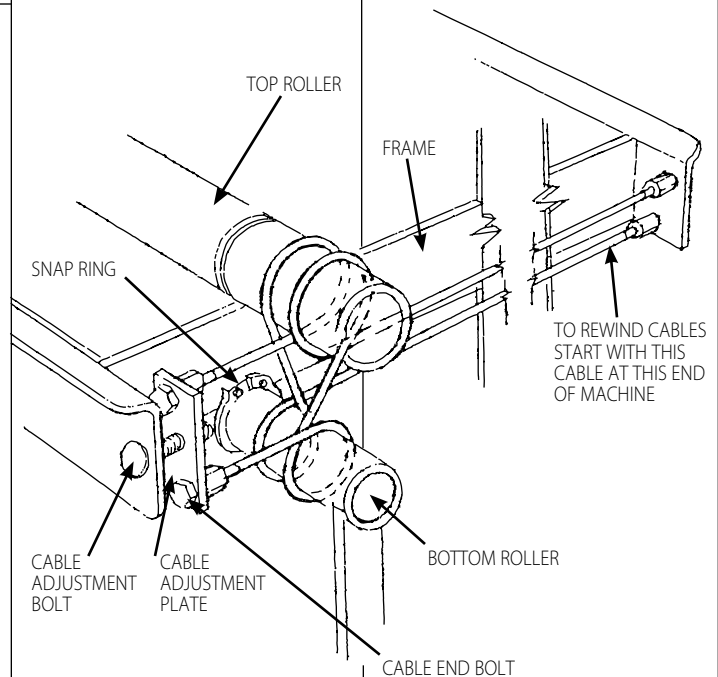

SRC PARTS LIST

Stock #	Description	# Per
22668G	Leg Set	Opt.
22657B	Cable, One Only	4
22694N	Cable, Set of 4	4
22654R	Handle, Wood	1
22651M	1/4" Shim	1
22650L	1/4" Shim w/Canvas	1
22652N	1/8" Shim	1
22649K	Top Canvas	1

brent® MODEL SR-14

SET UP:

1. Set slab roller on a **STURDY** bench and find the four rubber feet, four small screws, star washers and nuts in the parts bag. Lift up one end at a time and fasten the rubber feet through the 1/4" holes in the bottoms of the end plates with hardware provided.

2. Find the two allen set screws and hex wrench in the small parts bag. These screws secure the handle to the shaft. Slide the handle onto the shaft and line up the threaded holes in the handle with the drilled holes in the shaft. Insert the set screws and tighten securely.

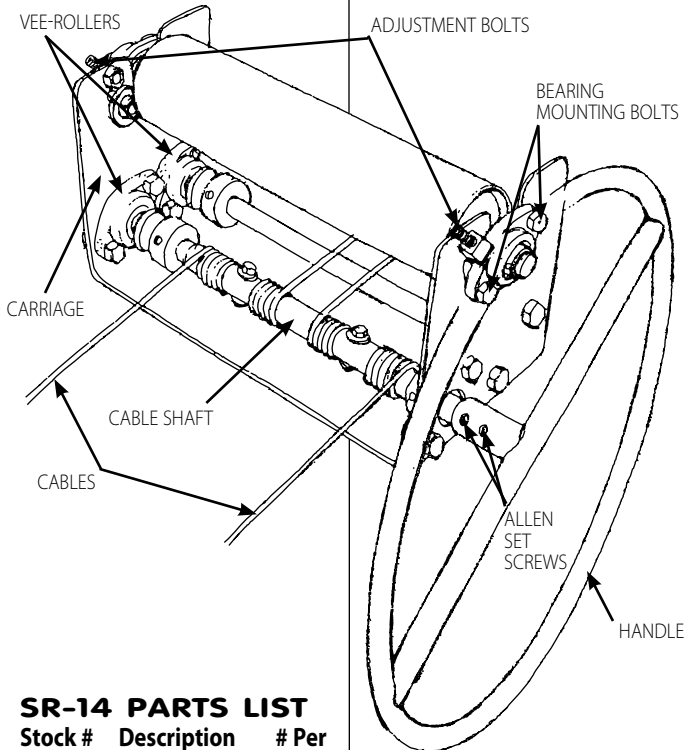

SR-14 PARTS LIST

Stock #	Description	# Per
22620A	Leg Set	Opt.
22052N	Set of Cables	1
22349R	Handle, Painted	1
22522K	1/4" Shim w/Canvas	1
22523L	1/8" Shim	1
22149N	Top Canvas	1
22564M	SR-14 Handextruder Stand	opt.

SMALL PARTS

4	Rubber Feet (22273W)
4	6-32 x 1/2 Screws
4	6-32 Nuts w/Star Washers
2	5/16-18 x 1/2 Set Screws
1	5/32 Allen Wrench
1	3/32 Allen Wrench

SMALL PARTS LEG SET ONLY

4	Leg Caps WW13
8	5/16-18 x 2 Bolts
8	5/16 Flat Washers
8	5/16 Lock Washers
8	5/16-18 Nuts
1	1/4" Allen Wrench

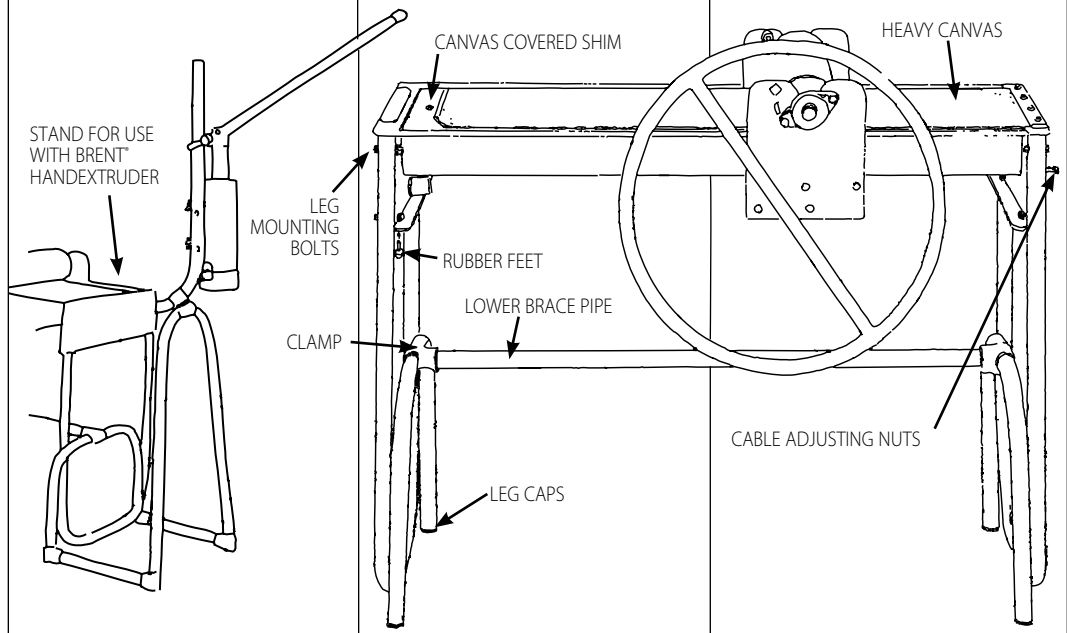

MAINTENANCE:

1. Normal maintenance for the SR-14 slab roller consists of lubricating the cables and cable shaft that winds up the cables with automotive chassis grease. Use the same lubricant on the vee-rollers and their tracks. Frequency of lubrication depends on how hard you use the machine. Visually check the cables, shaft, vee-rollers and tracks periodically to see if they are greasy. If they are not greasy, wipe on some grease (not too much or it will just fall off).

2. Periodically lift up on each side of the carriage to see if there is any play between the roller and the frame. If there is, slightly loosen the bearing mounting bolts on each side of the roller and turn the adjustment bolts clockwise with a 3/16 allen wrench until there is no play, but the carriage still rolls freely. Then tighten the bearing mounting bolts.

3. If the cables stretch out and become loose on your machine tighten them by first loosening the four locking nuts on the insides of the frame ends and then rolling the carriage all the way to one end. Now tighten the cable nuts on the opposite end of the machine. Then roll the carriage to the other end and tighten the two cables on the opposite end.

4. If you have an older machine and it becomes very hard to crank, check the adjustment bolts (as in Step 2); they may be too tight. If this is not the case it is possible that the carriage is out of alignment with the frame. This is rare unless the machine has been abused. Check, either visually or with a carpenter's square, to see if the carriage and roller are at 90 degrees to the frame rails. If they are not, remove all of the masonite shims and the wood base from the frame so that you have access to the vee-rollers and shafts. Now loosen the bearing mounting bolts on each end of the roller and the adjustment bolts. Also loosen all the set screws in the vee-rollers (there may be one or two in each). Using the carpenter's square align the carriage to 90 degrees to the frame rails and tighten the adjustment bolts to hold everything in place. Now tighten all the set screws in the vee-rollers (also check the set screws in the bearings on the vee-roller shafts). Set the adjustment bolts so that the carriage rolls freely (as in Step 2) and tighten the bearing mounting bolts. Because of the forces put on the components of this machine during the clay rolling process it is necessary to tighten the bolts and the set screws very tightly. Re-assemble the wood base and shims.

brent® MODEL SR-20 AND SR-36

SET UP:

1. Remove all cardboard crating and cut metal bands. Roll carriage to one end of the slab roller, pull the heavy top canvas out from under the roller, and roll it up on itself and tape it to the outside of the frame. This will keep the canvas out of your way and off the greasy cables. Now remove the masonite shims and wood bed. Remove the steel zig-zag braces if your machine has them. Unscrew the four $\frac{5}{16}$ " lag screws that hold the machine to the pallet and lift the machine off, but be sure to get help as it is heavy!

2. Tilt the slab roller up on its side (the opposite side from the handle shaft and label) and have a friend steady it while you bolt on one leg set with the smaller bent pipe inward. Put nuts on the outside so the bolt ends don't catch your clothes. Now bolt the second leg set on while sliding the lower brace pipe over the short projections on each leg set. Tighten all leg securing bolts tightly. Now tighten the allen screws on the ends of the lower brace pipe. Insert the plastic feet into the ends of the pipe legs. Get a friend and roll the machine onto its feet. Replace the zig-zag braces, the wood bed and the masonite shims.

3. Slide the circular handle onto the end of the cable shaft, making sure that the set screws line up with the drilled dimples in the shaft. Tighten both set screws very tightly with the allen wrench included in the parts bag.

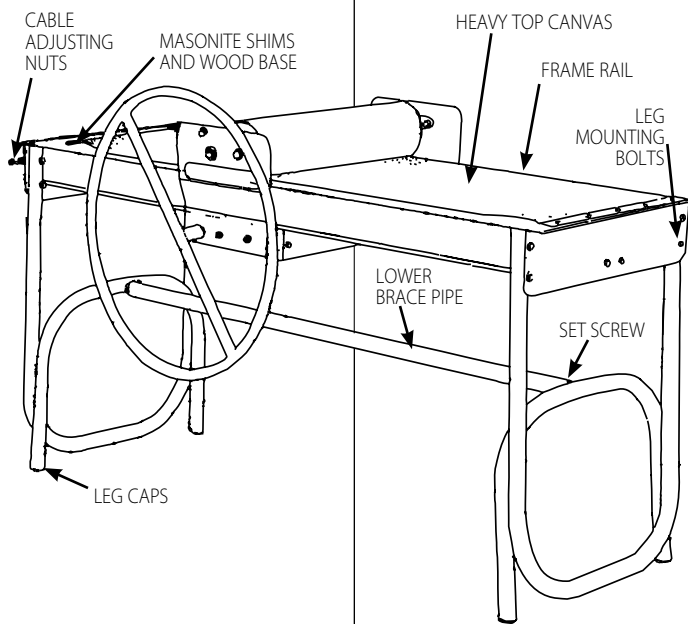

SR-36 PARTS LIST

Stock #	Description	# Per
22256A	Set of Cables	1
22353X	Handle, Painted	1
22535C	$\frac{1}{4}$ " Shim	1
22534B	$\frac{1}{4}$ " Shim w/Canvas	1
22533A	$\frac{1}{8}$ " Shim	1
22151R	Top Canvas	1
22566P	SR-36 Handextruder Stand	Opt.

SR-20 PARTS LIST

Stock #	Description	# Per
22256A	Set of Cables	1
22353X	Handle, Painted	1
22527R	$\frac{1}{4}$ " Shim w/Canvas	1
22526P	$\frac{1}{8}$ " Shim	1
22150P	Top Canvas	1
22565N	SR-20 Handextruder Stand	Opt.

MAINTENANCE:

1. Normal maintenance for the slab roller consists of lubricating the cables and cable shaft that winds up the cables with automotive chassis grease. Use the same lubricant on the vee-rollers and their tracks. Frequency of lubrication depends on how hard you use the machine. Visually check the cables, shaft, vee-rollers and tracks periodically to see if they are greasy. If they are not greasy, wipe on some grease (not too much or it will just fall off).

2. Periodically lift up on each side of the carriage to see if there is any play between the roller and the frame. If there is, slightly loosen the bearing mounting bolts on each side of the roller and turn the adjustment bolts clockwise with a $\frac{3}{16}$ allen wrench until there is no play, but the carriage still rolls freely. Then tighten the bearing mounting bolts.

3. If the cables stretch out and become loose on your machine, tighten them by first loosening the four locking nuts on the insides of the frame ends and then rolling the carriage all the way to one end. Now tighten the cable nuts on the opposite end of the machine. Then roll the carriage to the other end and tighten the two cables on the opposite end.

4. If you have an older machine

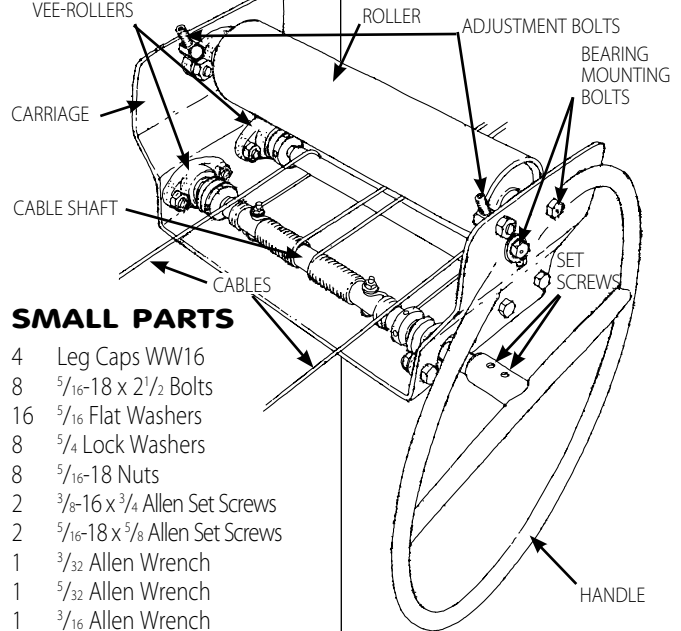

SMALL PARTS

4	Leg Caps WW16
8	$\frac{5}{16}$ -18 x 2 $\frac{1}{2}$ Bolts
16	$\frac{5}{16}$ Flat Washers
8	$\frac{3}{4}$ Lock Washers
8	$\frac{5}{16}$ -18 Nuts
2	$\frac{3}{8}$ -16 x $\frac{3}{4}$ Allen Set Screws
2	$\frac{5}{16}$ -18 x $\frac{5}{8}$ Allen Set Screws
1	$\frac{3}{32}$ Allen Wrench
1	$\frac{5}{32}$ Allen Wrench
1	$\frac{3}{16}$ Allen Wrench

and it becomes very hard to crank, check the adjustment bolts (as in Step 2); they may be too tight. If this is not the case it is possible that the carriage is out of alignment with the frame. This is rare unless the machine has been abused. Check, either visually or with a carpenter's square, to see if the carriage and roller are at 90 degrees to the frame rails. If they are not, remove all of the masonite shims and the wood base from the frame so that you have access to the vee-rollers and shafts. Now loosen the bearing mounting bolts on each end of the roller and the adjustment bolts. Also loosen all the set screws in the vee-rollers (there may be one or two in each). Using the carpenter's square, align the carriage to 90 degrees to the frame rails and tighten the adjustment bolts to hold everything in place. Now tighten all the set screws in the vee-rollers (also check the set screws in the bearings on the vee-roller shafts). Set the adjustment bolts so that the carriage rolls freely (as in Step 2) and tighten the bearing mounting bolts. Because of the forces put on the components of this machine during the clay rolling process it is necessary to tighten the bolts and the set screws very tightly. Re-assemble the wood base and shims.

HOW TO USE THE brent® SRC, SR-14, SR-20, SR-36

To use the slab roller, crank SRC (or turn the wheel on SR-14, 20, & 36) to move the top roller all the way to the end of the machine where the heavy top canvas is attached to the bed.

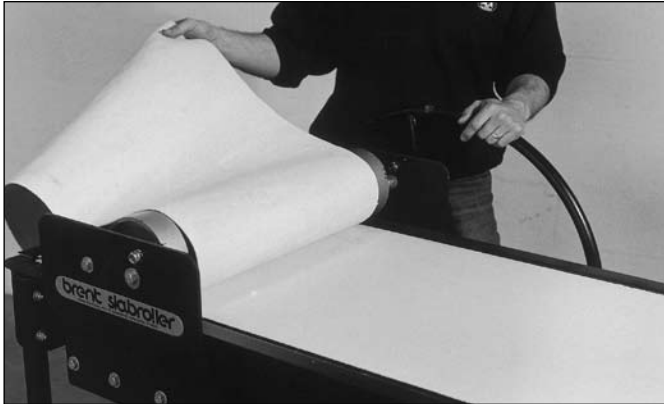

Figure 1

Flip the heavy canvas back over the roller (Figure 1). Masonite shims are used to raise or lower the bed to create your desired slab thickness. Remove or add masonite shims until you have the slab thickness you want (the space between the top canvas shim and the top roller) (Figure 2). Make sure the top shim has its canvas side up so the clay doesn't stick to it.



Figure 2

Place the clay firmly up against the roller. The shape of the clay will determine the size of the slab. Lay the canvas back over the clay. Be sure to straighten the canvas

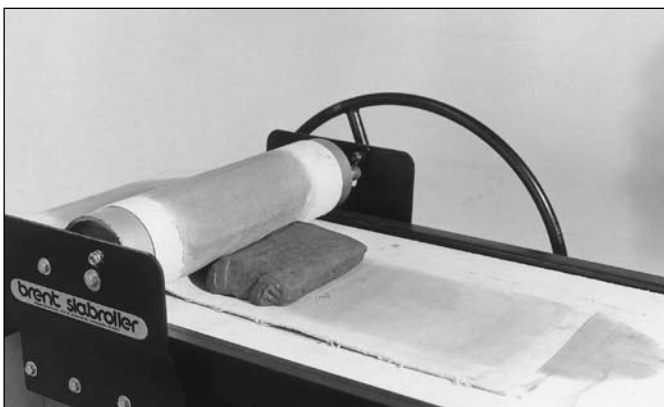

Figure 3

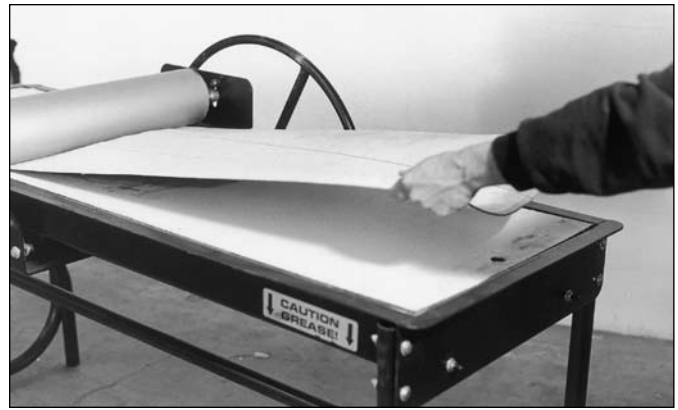

Figure 4

so it lays in the middle of the bed (Figure 3). The top roller will crush and fray the top canvas if it is caught in the frame edge and under the roller (Figure 4). Next, turn the handle. When the slab is rolled out, return the carriage to its original position, peel off the top canvas and lay it back over the roller. When returning the roller (carriage) do not slam it against the end of the frame as this can cause early cable breakage. The clay can be transported from the slab roller to your work area by removing the top shim (Figure 5).

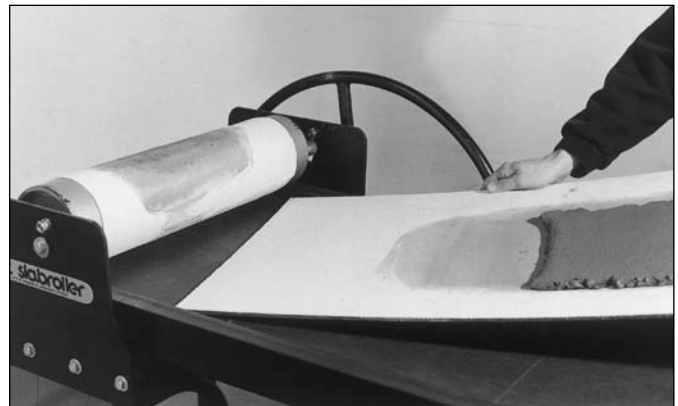

Figure 5

SPECIAL NOTES

If you are using very wet clay or rolling a lot of slabs continuously, you may want to purchase extra canvas covered shims. This will allow you to put in a dry shim every few slabs without

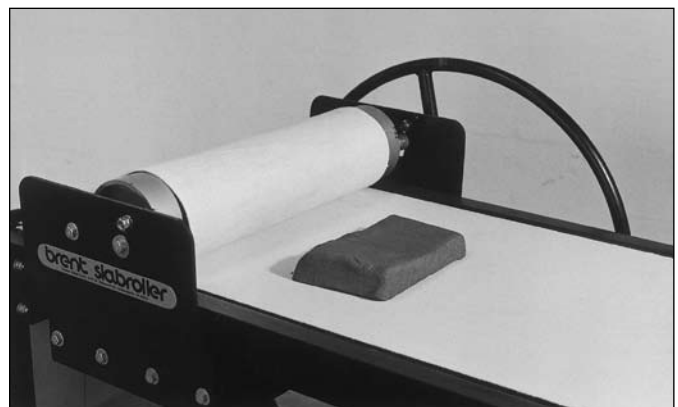

Figure 6

having to wait for one to dry. With extra canvas shims you can also remove the slab and the top shim together then put in another shim which will allow you to use the slab roller continuously. Shims should also be changed when changing clay bodies. Example: Shims for red clay bodies should be kept separate from shims for white clay bodies. Those of you who use only one clay body will have no contamination problem.



Figure 7

The shape of the clay placed on the roller will determine the shape of the slab produced, i.e. — a clay rectangle with the wide side parallel to roller will produce a wide, short slab (Figure 6 and 7). A clay rectangle with the narrow end against the roller will produce a long, narrow slab (Figure 8).

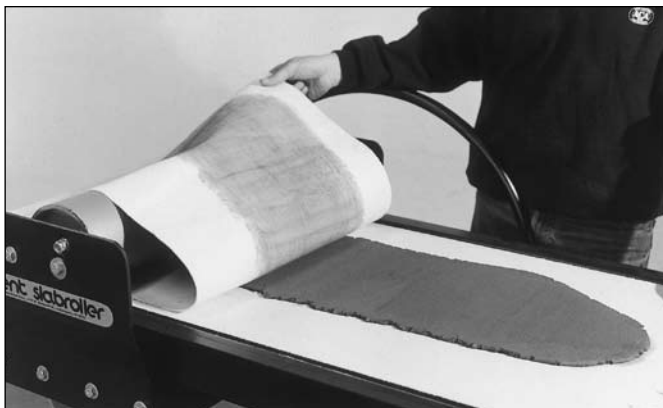

Figure 8

Stress can be lowered on the cables and the clay by angling the clay placed on the bed against the roller. We also suggest you limit the height of the piece of clay placed on the bed (2½-3 inches should be the highest) — flatter pieces will produce less stress on the cables and the clay.

Smaller heavy canvases (such as a top canvas) can also be used on the slab roller bed (Figure 9). They will allow you to remove clay slabs without removing the shims (Figure 10). Special care should be used in handling any slabs. The flatter you can keep the slab the less stress on the clay. This will generally create less warpage when the slab dries. A good method to handle clay slabs on heavy canvas (Figure 5) is to place a board under the canvas. Once the slab is rolled lay newspaper on top of the clay slab, then place a board, same size, on top. The slab

will be sandwiched between the boards. Take the two boards between your hands and flip them over using enough pressure in your hands to keep the slab from moving. Remove the (now) top board and peel off the canvas for future use. This method will allow you to handle the slab and transport it to your work area with minimal stress on the slab. The newspaper will keep the slab from sticking to the board.

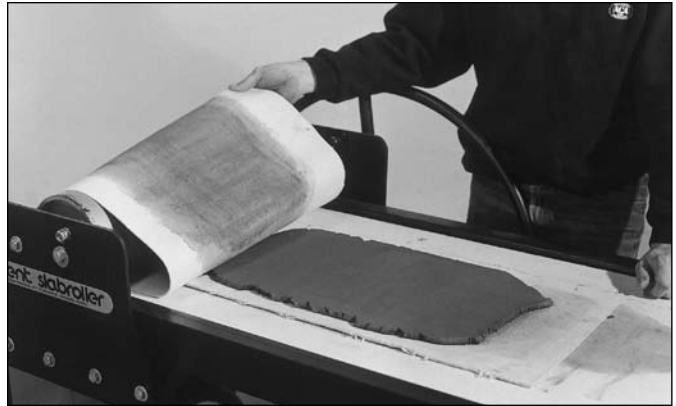

Figure 9

Different textures can be produced onto the slabs by using different canvases and linens, or other cloths. Examples: sheets will produce a very smooth surface compared to the surface created by the top canvas. The softer and thinner the material, the more care will be needed to create a surface without wrinkles. Other objects can also be used to press into the surface after the original slab is rolled. Examples are leaves, flowers, screens, etc. We have heard from people who use our slab rollers as printing presses by using felt blankets and thoroughly removing all the clay from the roller.

We're sure you will have many other ideas once you have used the slab roller for a short period of time and realize its possibilities.



Figure 10

FOR YOUR SAFETY

NEVER put hands under or near roller when adjusting your shims and canvas or positioning the clay as others may turn the handle or wheel. When rolling the clay, the same applies—**KEEP HANDS, HAIR, CLOTHES AWAY FROM ROLLER AND CARRIAGE. MODEL SRC: KEEP HANDS, HAIR AND CLOTHES AWAY FROM CABLES AND MOVING PARTS.**

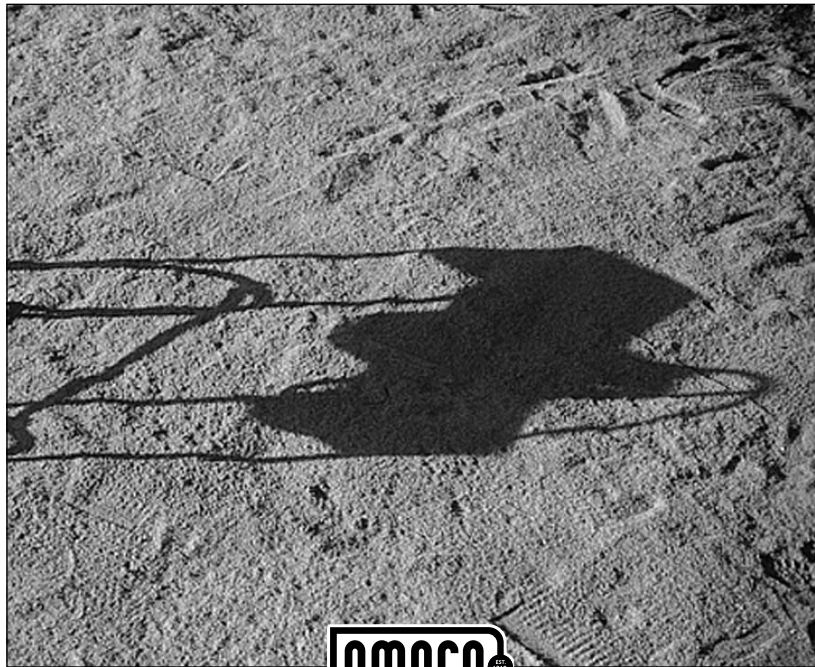

American Art Clay Co., Inc.

6060 Guion Road • Indianapolis, Indiana 46254-1222 USA
(800) 374-1600 • Fax: (317) 248-9300 • www.amaco.com