

AMACO® High Fire Electric Kiln HF-101

208 or 220-240 Volts AC, Single Phase & Three Phase

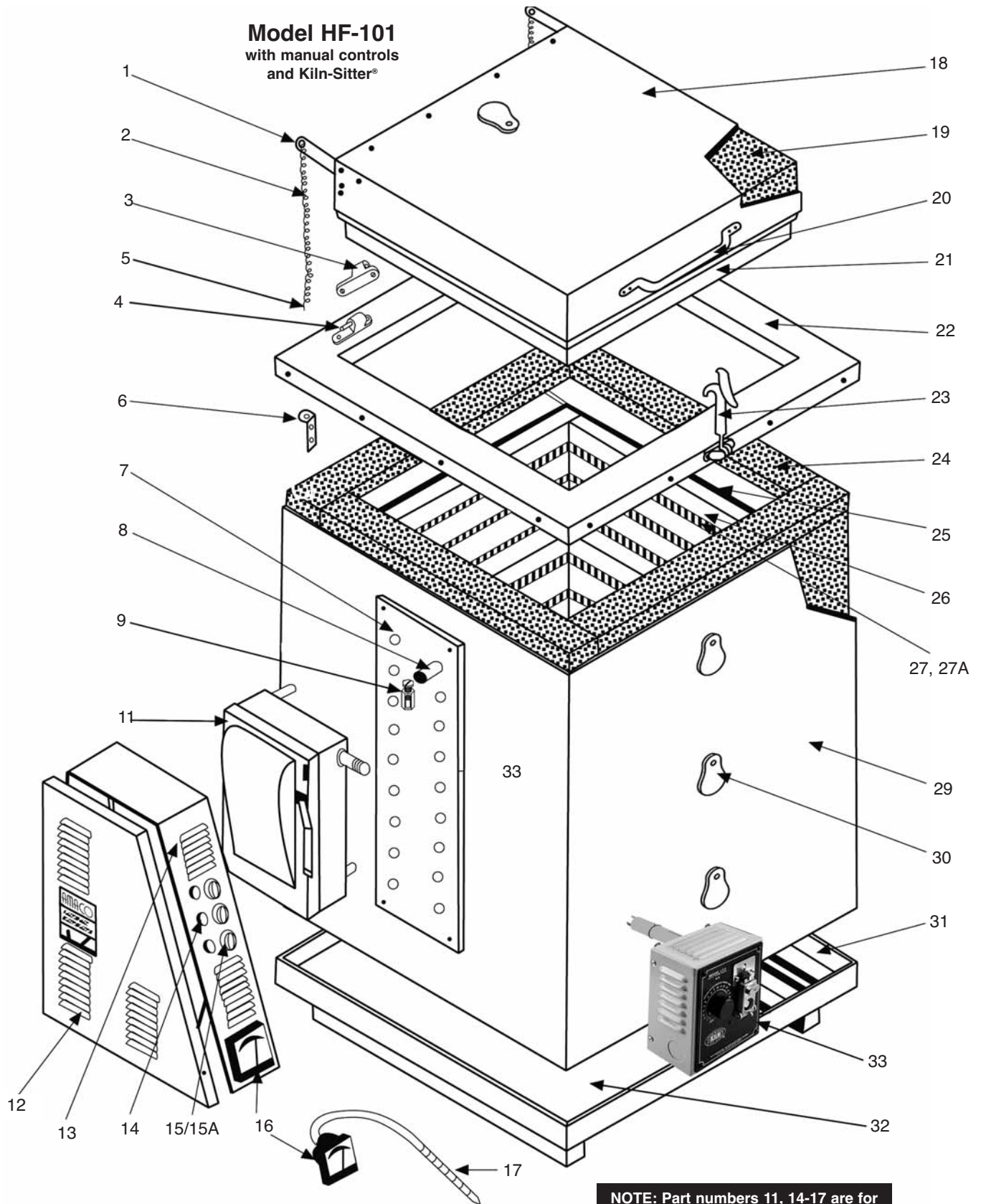

NOTE: Part numbers 11, 14-17 are for Kiln-Sitter models only. See page 3 for Select Fire™ diagram and parts list.

General Information

The AMACO® HF-101 High Fire Kiln has a maximum attainable temperature of Cone 8 (2320°F, 1271°C). The average fast-fire time required for this kiln to reach 1950°F (1066°C) is 7 hours. The HF-101 is available with three infinite control switches or the Select Fire™ Computer Control for precise control, convenience, and consistent results firing after firing. During every firing, pyrometric cones should be placed in the kiln so that they can be viewed through the peephole(s).

This booklet contains a wiring diagram for the HF-101 kiln, Select Fire™ Controller (single and three phase) and a parts list with accompanying drawing for the HF-101 and Select Fire™. Before installing the kiln, consult these diagrams for recommendations on electric service, fuses, etc.

Also included with this booklet is an AMACO® Electric Kilns Installation/Operation/Maintenance manual which includes important information about selecting a location for your kiln, firing guidelines, do-it-yourself instructions for replacing elements and complete programming and operating instructions for the Select Fire™ Controller.

Operating Information for Manual Models with Kiln-Sitter®

The Amaco® HF-101 high fire kiln is equipped with a fused safety switch box and three infinite control switches. A pilot light indicates when the kiln is operating.

Close kiln door and latch securely before firing. Turn safety switch to "ON", place the appropriate cone in the Kiln-Sitter®, and push the plunger button. NOTE: If the kiln is equipped with a KilnVent, it must be turned on prior to firing.

The infinite control switches operate as follows:

- LOW: All switches on "Low"
- MEDIUM: All switches on "6"
- HIGH: All switches on "High"

The time required for firing will depend on the temperature to be attained, the number of objects being fired, and electric current fluctuations. Approximate cycle times are as follows:

- LOW: approximately 1/2 hour
- MEDIUM: approximately 1/2 hour
- HIGH: until desired temperature is reached

When firing time has been completed, turn off all switches and allow the kiln to cool overnight. If glazed pieces are removed from the kiln when the pieces are too hot, crazing may result due to sudden cooling. NOTE: Kilns equipped with a KilnVent will cool faster.

Installation of Kiln

Place kiln at least 18 inches from any existing wall at the sides and back. Connect kiln to an electric circuit which corresponds to that stamped on the kiln name plate. No. 6 gauge wire or larger should run from the power supply to the fused safety switch box on the kiln. Fuse requirements:

- Single Phase, 208V 55
- Single Phase, 240V 45
- Three Phase, 208V 35
- Three Phase, 240V 30

KILN SPECIFICATIONS HF-101

(Single and three phase unless otherwise noted)

Voltage	208 or 220-240 volts AC only
Amp Rating	43 at 208V, 37.5 at 240V single phase; 25 at 208V, 24 at 240V three phase
Kilowatt Rating	9.0
Firing Speed Control	Three Infinite Control Switches or Select Fire™
Maximum Temperature	2320°F, 1271°C
Firing Chamber Dimensions (W x D x H)	18" x 18" x 27"
Firing Chamber Area	5.06 cubic feet
Exterior Dimensions (W x D x H)	34" x 29 ⁵ / ₈ " x 40 ¹ / ₂ "
Elements.....	9 Wire Coils
Shipping Weight	546 lbs.

Ordering Replacement Parts: when ordering replacement parts for this kiln, be sure to specify the Model Number, Serial Number and Voltage.

REPLACEMENT PARTS LIST

SELECT FIRE™ COMPUTER CONTROL

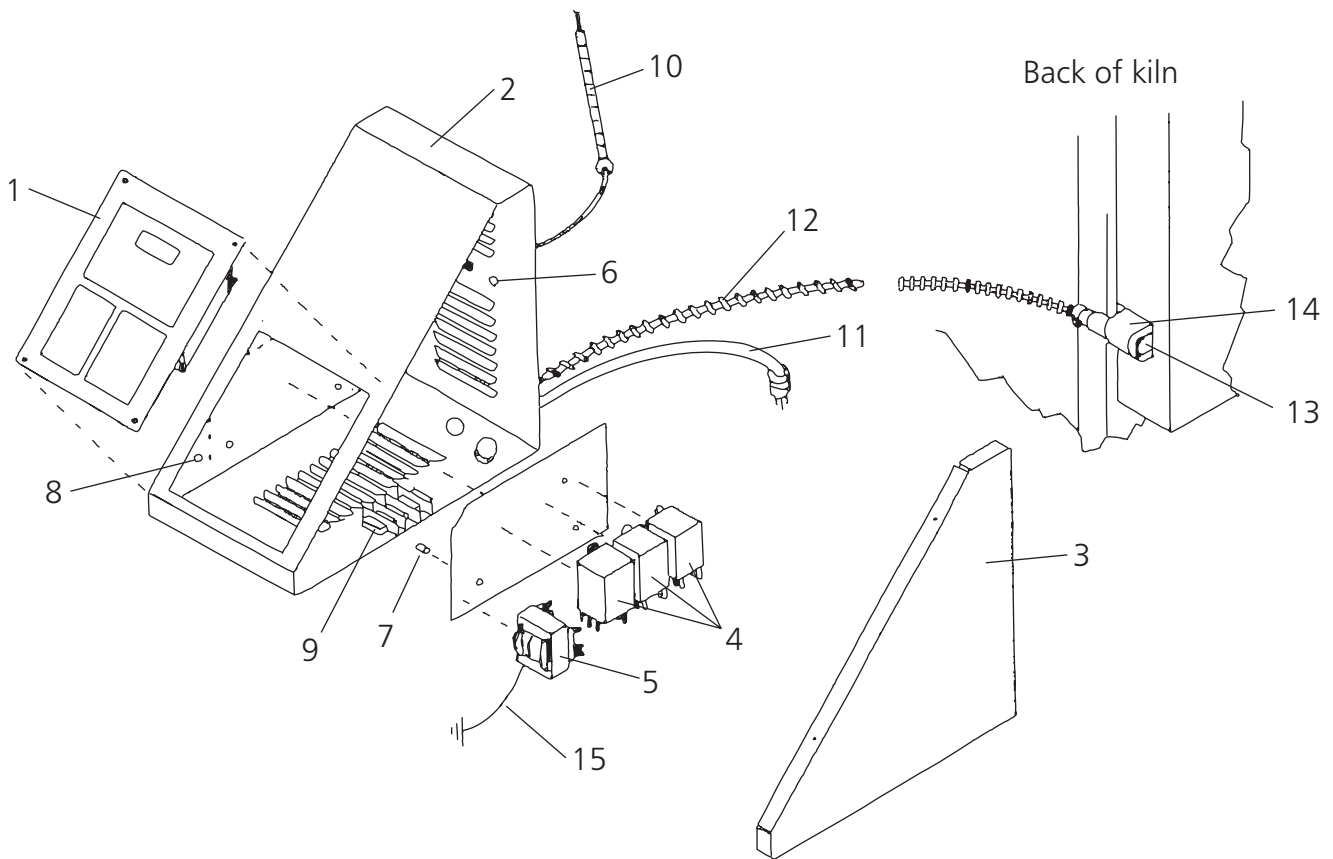

1	24250P	Select Fire Control	1
2	*	Select Fire Control Box	1
3	*	Select Fire Control Box Cover	1
4	24276H	Relays	3
5	24278K	Transformer	1
6	22134W	Fuse Holder	1
7	*	3/16" spacer	3
8	*	5/8" spacer	3
9	27749M	Terminal Block, 60 amp	1
10	28845T	Thermocouple, 72" long lead wire	1
11	27759A	Power cord with plug, single phase	1
11	28674D	Power cord with plug, three phase	1
12	*	Power to coils	1
13	28418L	Conduit Fitting	1
14	28419M	Conduit Cover	1
15	*	Ground (14 gauge wire)	1

*Special order item. Allow extra time for shipment.

REPLACEMENT PARTS LIST

AMACO® HIGH FIRE ECONOMY ELECTRIC KILN HF-101

DETAIL NO.	PART NO.	DESCRIPTION	PARTS/ KILN
	29754R	Door Complete – No Hardware	
1	29231B	Spring Arm	2
2	29232C	Spring	2
3	28073H	Hinge without pin	4
4	28072G	Hinge Pin	2
5	29264M	Eyebolt	2
6	29233D	Spring Bracket	2
7	29827X	CEM-FIL	1
8	28069D	Insulator #PT-12	18
9	28077M**	Terminal Lug #10 NPW	18
11	28108W+	Safety Switch 60 Amp 3 Ph. (ITE JN 422C) – Kiln-Sitter® models only	1
12	*	Terminal Guard Cover	1
13	*	Terminal Guard	1
14	28074J	Pilot Light Assembly 240V – Kiln-Sitter® models only	3
15	28128E	Switch Knob – Kiln-Sitter® models only	3
15A	28068C	Infinite Heat Control Switch 240V – Kiln-Sitter® models only	3 N/S
16	28825W	Pyrometer – Kiln-Sitter® models only	1
17	28842B	Thermocouple, 48" long, 7" probe – Kiln-Sitter® models only	1
18	*	Door Shell	1
19	29783M	Lid Insulation Set	1 Set
20	28129H	Lid Handle	1
21	29784C	Lid Brick Set	1 Set
22	*	Top Frame	1
23	28153X	Lid Latch	1
24		Top Frame Insulation	
25	29278C	Fiberfrax Rope	1
26	29780X	Side Brick: Section for Top, Middle or Bottom	12
27	29775B	Element Coils 208V	9
27A	29777E	Element Coils 240V	9
29	*	Kiln Shell	1
30	29025C	Peephole Cover	4
31	*	Bottom Frame	1
32	*	Kiln Bottom	1
33	28741B	Kiln Sitter®, LT-3 Model with Limit Timer, 208, 220/240 Volts, Single Phase Kiln-Sitter® models only	1
33	28739Y	Kiln Sitter® with Limit Timer and Relay, 208, 220/240 Volts, Three Phase Kiln-Sitter® models only	1
	29976T	KilnVent-Suspended Version, 115 Volt, 1.1 Amp (optional)	1
	29968J	Master KilnVent, 115 Volt, 1.1 Amp (optional)	1
	24122S	Select Fire (Wall Mount), Single Phase (optional)	1
	24123T	Select Fire (Wall Mount), Three Phase (optional)	1

* Special Order Item. Allow extra time for shipment.

+ Standard Hardware/Electrical Item available locally.

** Available only in Packages of Twelve each.

Prices available upon request.



American Art Clay Co., Inc. • 6060 Guion Rd., Indianapolis, IN 46254
(800) 374-1600 • www.amaco.com • Email: TalkToUs@amaco.com

AMACO® High Fire Electric Kiln HF-101

Manual Control Models
208 or 220-240 Volts AC, Single Phase

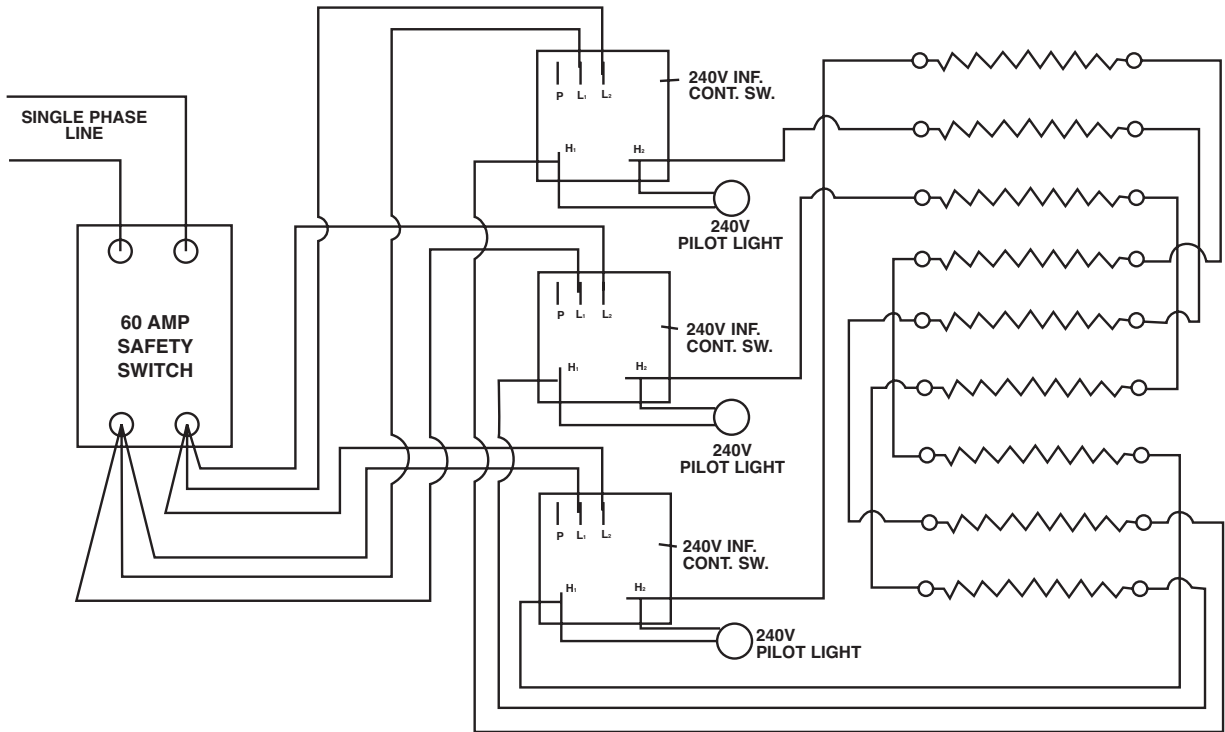

208 or 220-240 Volts AC, Three Phase

